

P30 Series

Mechanical Grout and Concrete Pump

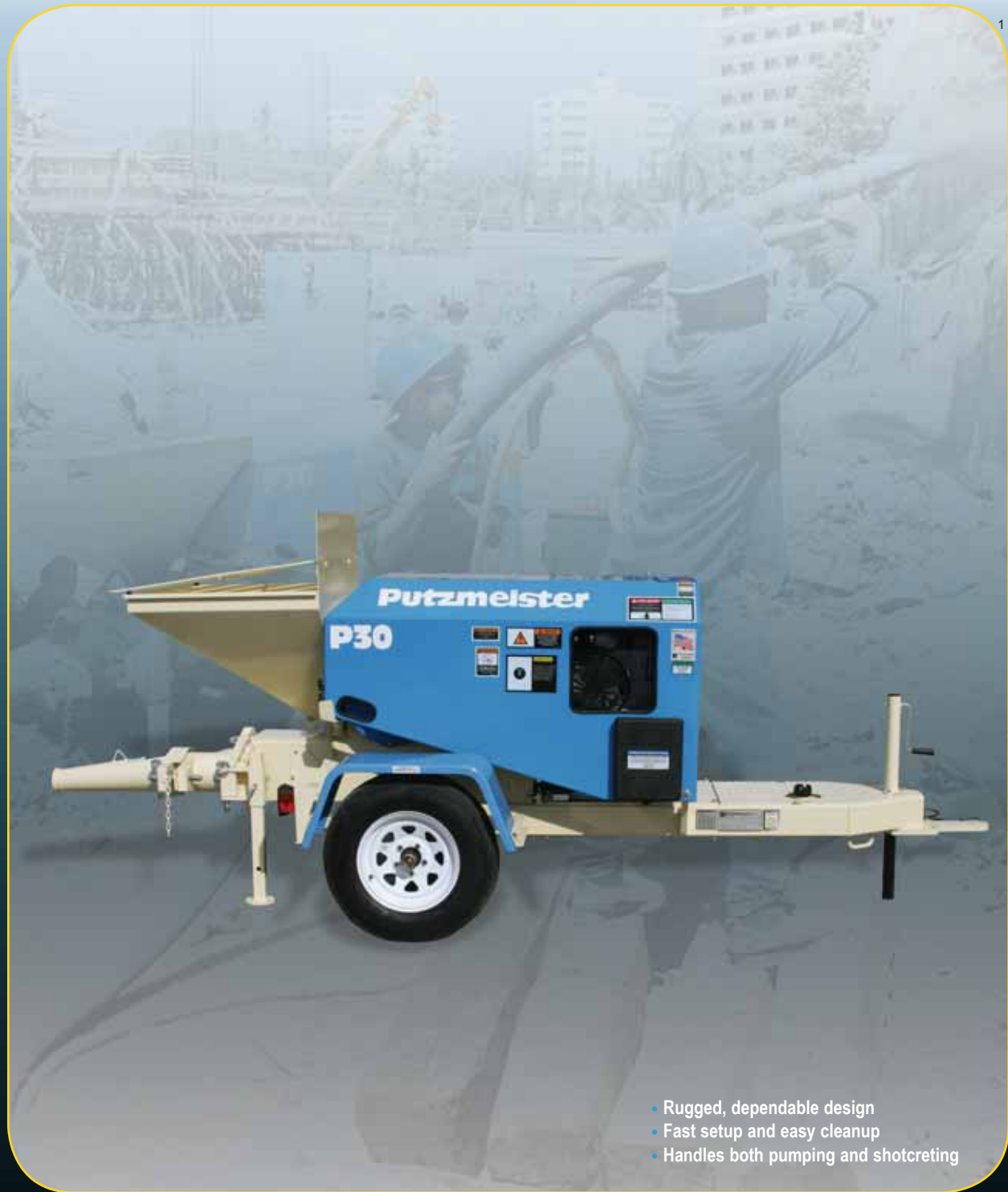

- Rugged, dependable design
- Fast setup and easy cleanup
- Handles both pumping and shotcreting

P30 Series

P30 Series

P30 Series

P30D (Diesel) • P30E (Electric)

Specifications

Performance	
Pump type	Mechanical Ball Valve
Concrete valve	Ball/Seat
Maximum aggregate size	1/2" minus (-12mm)
Volume output	25 yd ³ /hr (19m ³ /hr)
Maximum concrete pressure*	425 psi (29 bar)
Maximum pumping distance*	400' (125m)
Maximum pumping height*	100' (30m)
Maximum strokes per minute	135
Engine	
Standard diesel power	Hatz 2M41LZ 37 hp (27kW)
Optional electric power	20 hp (15kW)
Technical Information	
Outlet diameter	3" HD (76mm)
Concrete cylinder diameter	6" (152mm)
Concrete cylinder stroke	12" (305mm)
Standard fuel capacity	18 gal (68L)
Hopper height	50" (1.27m)
Hopper capacity	6 ft ³ (170L)
Length	145" (3.68m)
Width	60" (1.52m)
Height	63" (1.60m)
Weight (approx)**	2500 lbs (1136kg)
Tire size	ST205/75 D14
Standard remote control cable	250' (76m)

*These figures will vary due to differences in mix design, line size and job site conditions. Full pressure and volume cannot be attained simultaneously. All specifications are subject to change without notice.

**Weights vary with options selected.



Single-piece formed and hardened crankshaft offers longer life and smoother performance.



Heavy-duty boxed tubular steel frame is both strong and rigid to ensure smoother towing.



Wedge-style manifold design with fixed stop pins swings open for service.



Putzmeister America, Inc.
1733 90th Street
Sturtevant, WI 53177 USA
Telephone (262) 886-3200
(800) 884-7210
Facsimile (262) 884-6338
www.putzmeister.com



Authorized Distributor

Putzmeister

P30 Series: Rugged, Simple, Dependable



² A cost-effective solution for your concrete and grout pumping challenges, Putzmeister's rugged P30 Series can pump 1/2" (12mm) minus aggregate up to 25 yd³/hr (19m³/hr). With an impressive range of standard features and the precision engineering you need for consistent results, the P30 is a mechanical ball valve pump that is ideal for a variety of placing applications.

Designed to adapt to your specific application needs, Putzmeister's P30s are:

- Compact to pump patios, walkways, lightweight cellular concrete, grout, slurries and masonry block fill.
- Rugged enough to handle foundations, footings, pour-in-place walls, even shotcrete for pools and drainage systems.
- Built to last with quality components that will provide years of low maintenance productivity.
- Available with diesel or electric engines.



For faster setup, smoother pumping, easier cleanup and maximum dependability, look to Putzmeister — a leading force in concrete placement equipment worldwide. Call today and learn how our cost-effective P30 Series can increase your bottom line.

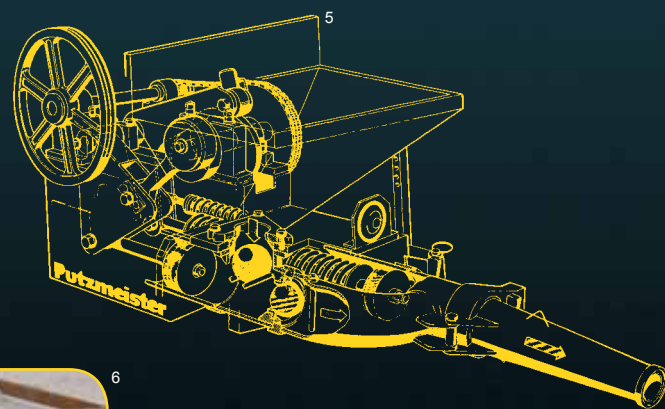

⁶ Popular, easy to maintain mechanical pump designed to minimize directional changes, improve concrete flow and reduce wear.

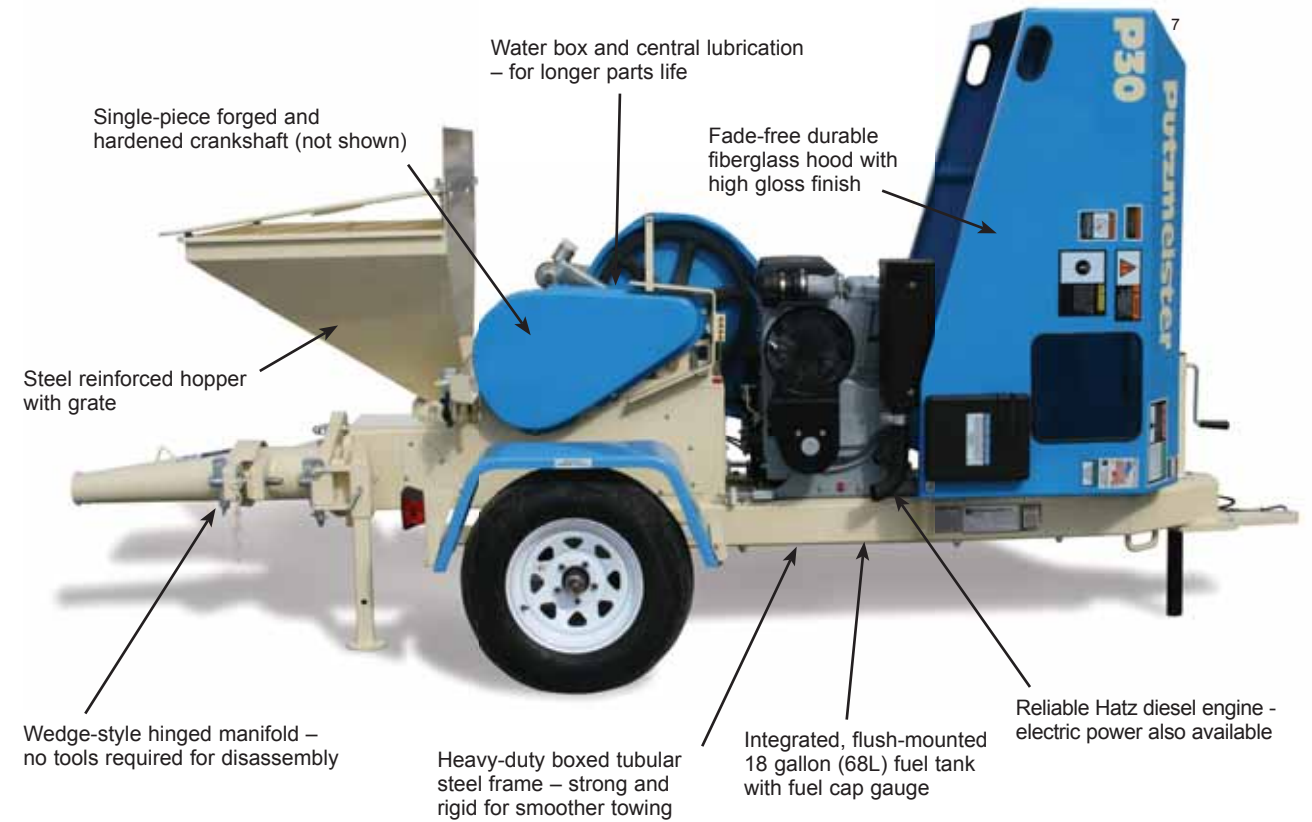

Handles a wide variety of applications including: Patios & Walkways • Lightweight Cellular Concrete • Grout • Slurries • Floorscreed • Columns • Slope Stabilization • Footings • Slab Jacking • Slabs • Piling • Masonry Block Fill • Foundations • Basements • Ditch Lining • Swimming Pools • Shotcreting